

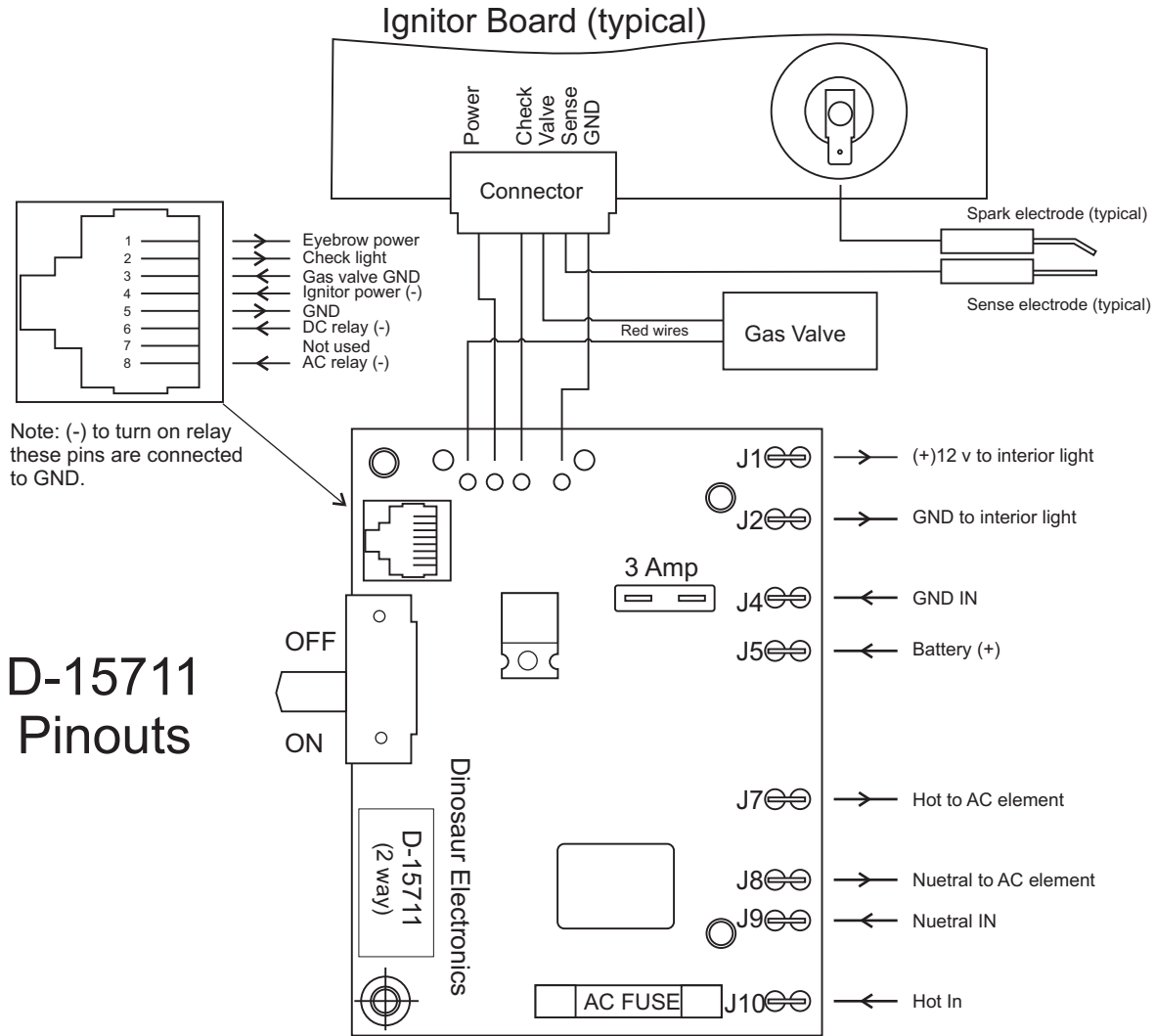

# Dinosaur Electronics

1160 SE 27th St.  
 Lincoln City, OR 97367  
 Ph. (541) 994-4344 Fax: (541) 994-2796

## D-15711 Replacement Instructions



## Cover Modification Instructions

**\*You will need to keep the original cover!**

Some modification of the original cover may be necessary to accommodate the storage switch on the new board. After you have removed the cover from the old circuit board, you will need to cut a notch in it using the template provided below.

