

# DINOSAUR ELECTRONICS

## IMT 24VAC Tester Manual

Third Edition



# Controls

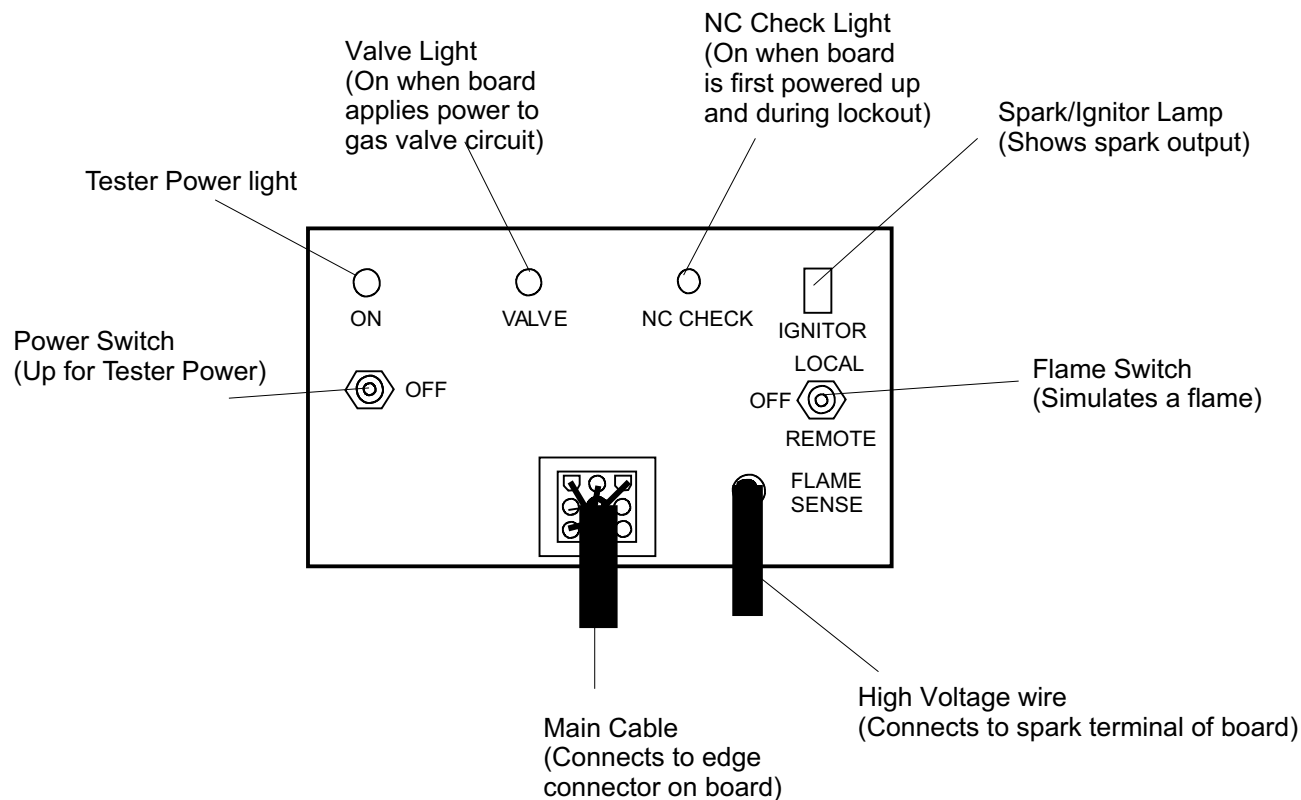

OEM part number	Tester model to use	Test routine	Delay Time sec.	Ignition time sec.	Ignition tries
05-169002-003	IMT-24 VAC	Remote	15 sec.	7 sec.	1 try
05-169003-103	IMT-24 VAC	Remote	15 sec.	7 sec.	1 try
05-169005-123	IMT-24 VAC	Remote	15 sec.	7 sec.	1 try
05-299000-153	IMT-24 VAC	Remote	15 sec.	7 sec.	1 try
05-299004-153	IMT-24 VAC	Remote	15 sec.	7 sec.	1 try
230608	IMT-24 VAC	Remote	15 sec.	7 sec.	1 try
316019	IMT-24 VAC	Remote	15 sec.	7 sec.	1 try
5119	IMT-24 VAC	Remote	15 sec.	7 sec.	1 try
7705-315	IMT-24 VAC	Remote	15 sec.	7 sec.	1 try
UIB 24 VAC	IMT-24 VAC	Local	17 sec.	7 sec.	3 try
Triton 2460D918-113	IMT-24 VAC	Local	15 sec.	7 sec.	3 try
Use the rest of this chart to compile additional Ignitor board information.					

Note: If you have a 24v AC board with a number which does not appear on the chart, try the Remote routine, and then the Local routine. The sense circuit should hold the valve open in one of these 2 positions.

# Hookup Diagram for the IMT cables.

The Main Cable and High Voltage Cable are used for all boards.  
The External Sense Clip is used when you need to test a board that has an external sense wire permanently attached.

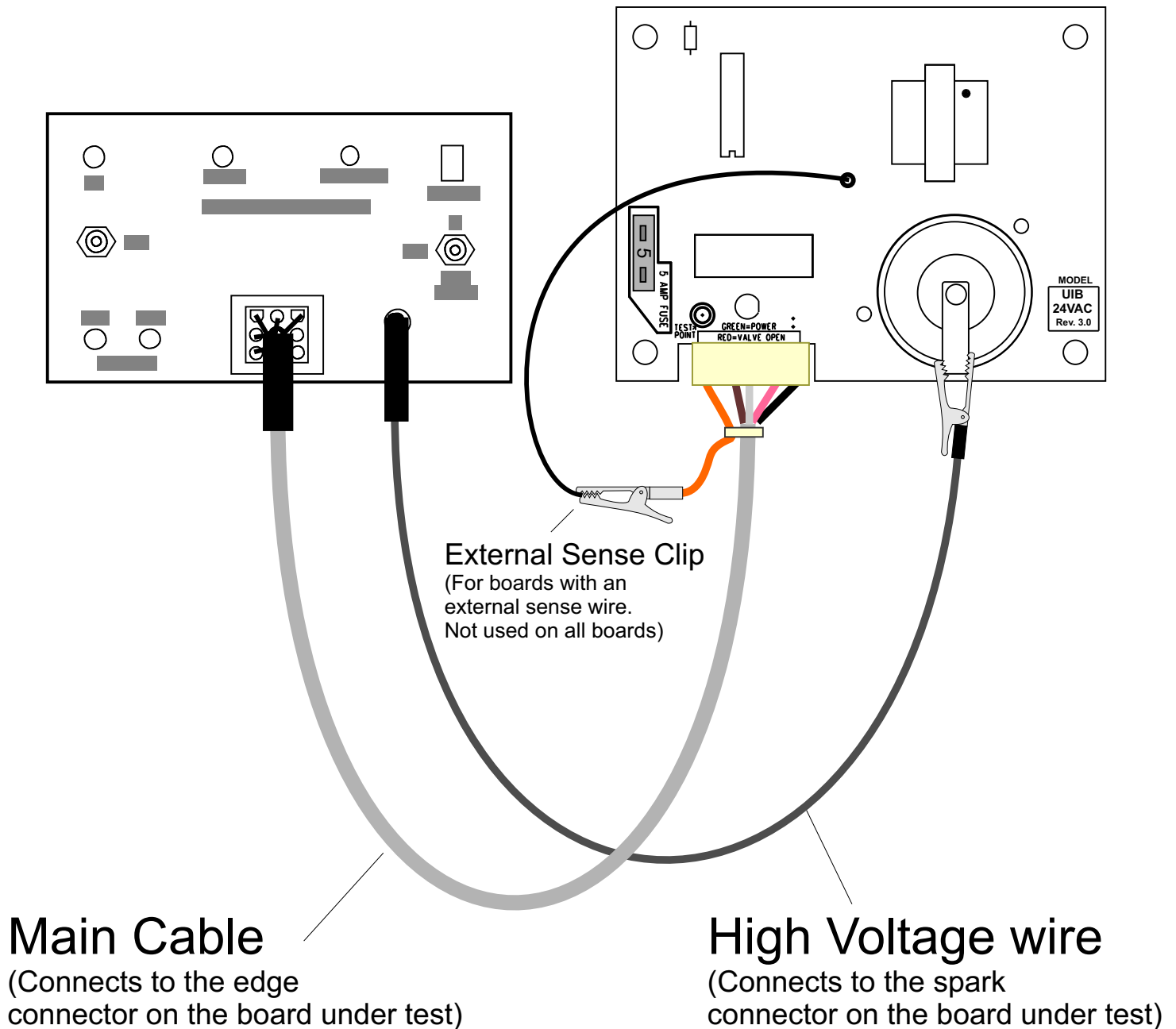

# Local Test Routine

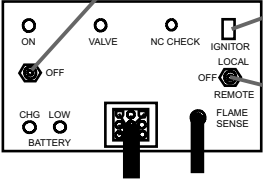
- 
1. Turn on Power Switch
  2. Wait for Spark  
Water Heater boards: 1-2 seconds  
Refrigerator boards: 1-2 seconds  
Furnace boards: 15-20 seconds
  3. Move Flame Switch up (Local position)
  4. Spark should stop, and valve should stay on as long as Flame Switch is in this position.
  5. Test is complete, but you can also do the following:
    - (a) Twist the board to check for intermittent solder connections.
    - (b) Turn off the Flame Switch and let the board complete all fire cycles and go into lockout.
- 

# Remote Test Routine

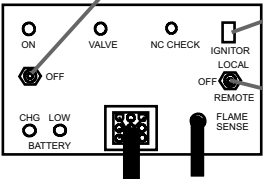
- 
1. Turn on Power Switch
  2. Wait for Spark  
Water Heater boards: 1-2 seconds  
Refrigerator boards: 1-2 seconds  
Furnace boards: 15-20 seconds
  3. Move the Flame Switch down (Remote position)
  4. Spark may or may not stop, and valve should stay on as long as the Flame Switch is in this position.
  5. Test is complete, but you can also do the following:
    - (a) Twist the board to check for intermittent solder connections.
    - (b) Turn off the Flame Switch and let the board complete all fire cycles and go into lockout.